

PROJECT FOR:

1st Christian Church

Balcony Railing

SOA PROJECT NUMBER: 17038

ISSUE FOR BID
June 26, 2017



06/26/2017

William H. Oswald - Architect
License No. A-5419

ARCHITECT

Simon Oswald Architecture
2801 Woodard Drive, Suite 103
Columbia, MO 65202
Phone: 573-443-1407

STRUCTURAL ENGINEER

Hardin Engineering
102 N Allen St. Suite 1
Centralia, MO 65240
Phone: 573-256-9005

SHEET LIST

COVER

A-1 = ARCHITECTURAL DETAILS & NOTES

S-1 = STRUCTURAL DETAILS & NOTES

STRUCTURAL DESIGN CALCULATIONS

05 7313 – GLAZED DECORATIVE METAL RAILINGS

06 1053 – MISCELLANEOUS ROUGH CARPENTRY

06 1600 – SHEATHING

09 9123 – INTERIOR PAINTING

PAGES

1

1

3

6

3

3

3

(This sheet intentionally blank)

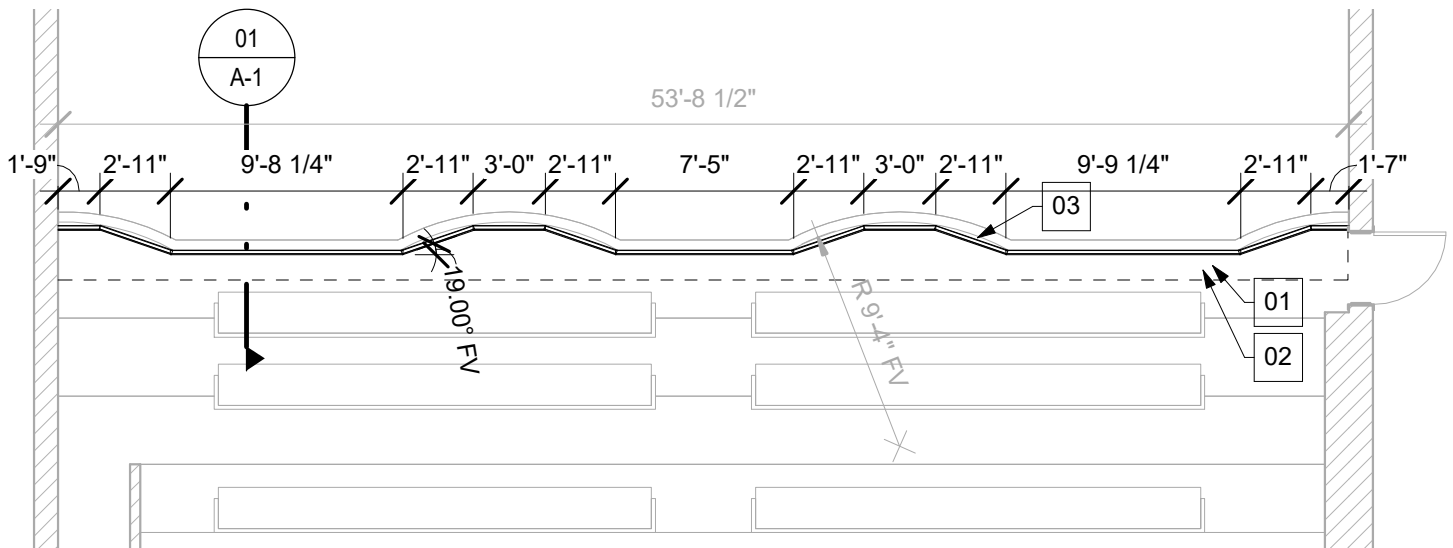

02 BALCONY FLOOR PLAN

A-1 1/8" = 1'-0"

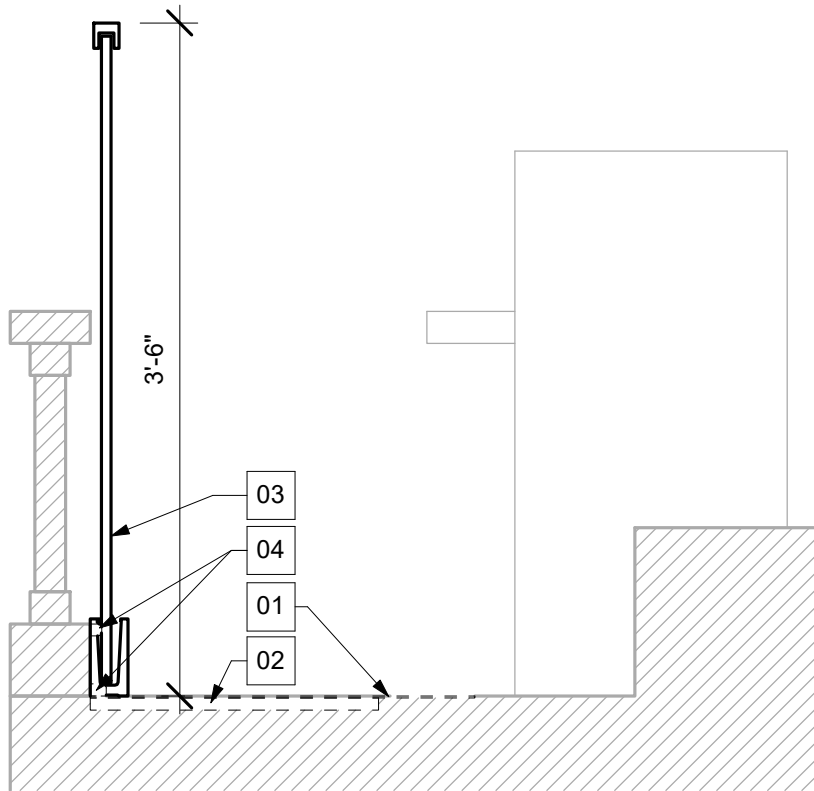

01 BALCONY RAILING SECTION



A-1 1" = 1'-0"

GENERAL NOTES

1. FIELD VERIFY ALL DIMENSIONS. IF DIMENSIONS VARY SIGNIFICANTLY NOTIFY THE ARCHITECT
2. ALL DIMENSIONS TO FACE OF EXISTING FINISH UNLESS NOTED OTHERWISE
3. GRAY ITEMS INDICATE EXISTING TO REMAIN - PROTECT DURING CONSTRUCTION.
4. REFER TO STRUCTURAL FOR ATTACHMENT REQUIREMENTS.

KEYNOTES

- 01 CARPET - REMOVE & SALVAGE FOR REINSTALLATION
- 02 SUBFLOOR - REMOVE AS NEEDED TO ACCOMODATE INSTALLATION OF 6X6 FRAMING BETWEEN FLOOR JOISTS - REFER TO STRUCTURAL. REINSTALL SUBFLOOR FLUSH WITH ADJACENT, AND MATCH EXISING.
- 03 GLAZED DECORATIVE METAL RAILING SYSTEM. BASE BID = CURVED TO FOLLOW EXISTING WOOD RAILING. DEDUCT ALTERNATE = SEGMENTED AS SHOWN ON PLAN
- 04 EXISTING SHOE TO BE REMOVED SO NEW RAILING CAN BE INSTALLED FLUSH WITH EXISTING WOOD RAILING

DETAILS AND NOTES A-1 SOA PROJECT: 17038	1ST CHRISTIAN CHURCH BALCONY RAILING 101 N 10th St, Columbia, MO 65201	 www.soa-inc.com 2801 Woodard Drive, Suite 103 Columbia, MO 65202 573.443.1407	 102 N Allen St, Suite 1 Centralia, MO 65240 573.256.9005	DATE 06/26/17

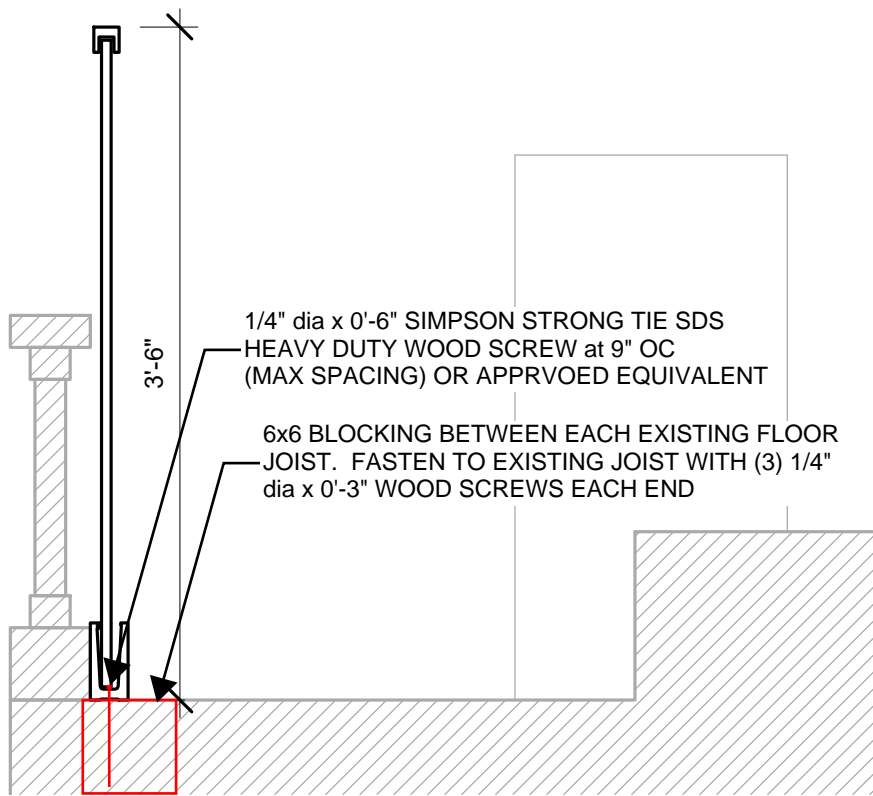

(This sheet intentionally blank)



01 BALCONY RAILING SECTION

S-1 1" = 1'-0"



S-1 SOA PROJECT: 17038	1ST CHRISTIAN CHURCH BALCONY RAILING 101 N 10th St, Columbia, MO 65201	 <small>www.soa-inc.com</small> 2801 Woodard Drive, Suite 103 Columbia, MO 65202 573.443.1407	 <small>HARDIN ENGINEERS ARCHITECTS</small> 102 N Allen St, Suite 1 Centralia, MO 65240 573.256.9005	DATE 06/26/17

(This sheet intentionally blank)

Structural Design Calculations

For

First Christian Church –
Guardrail

Columbia, MO



06/26/2017

Client: SOA, Inc.

GUARDRAIL

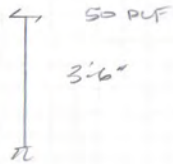

$$M = 50 \text{ PLF} (3'-6") = 175 \text{ ft} \cdot \text{lbs/ft} \quad (2100 \text{ in} \cdot \text{lbs/ft})$$

$$\text{Anchors @ } 9" \text{ OC} \approx 0.75'$$

$$M_a = 0.75' (m) = 131 \text{ ft} \cdot \text{lbs/ANCHOR} \quad (1572 \text{ in} \cdot \text{lbs/ANCHOR})$$

REDUCTION DUE TO LOAD DISTRIBUTION, $R = 0.5$

$$0.5 M_a = 65 \text{ ft} \cdot \text{lbs/ANCHOR} \quad (780 \text{ in} \cdot \text{lbs/ANCHOR})$$

$$\text{ROOT, } d \approx 3\frac{1}{2} = 1.5"$$

$$\text{ANCHOR TENSION, } T = M_a / d = 780 \text{ in} \cdot \text{lbs} / 1.5" = 520 \#$$

$$\text{SIMPSON STRONG TIE SDS WITHDRAW} = 172 \#/\text{IN}$$

$$1/4" \phi \times 6" \text{ SDS, } T_L = 3\frac{1}{2} \Rightarrow 3\frac{1}{4} (172 \#/\text{IN}) = 559 \# > 520 \# \therefore \text{OK}$$

USE: 1/4" ϕ x 6" SIMPSON SDS HEAVY DUTY WOOD SCREW

TABLE 4—CONNECTION GEOMETRY

CONDITION ¹		MINIMUM DISTANCE OR SPACING (in.)
Edge distance	Perpendicular to grain loading (Loaded or unloaded edge)	1 1/2
	Parallel to grain loading	1
End distance	Perpendicular to grain loading	4
	Parallel to grain loading (Loading toward or away from end)	3
Spacing (Loading parallel or perpendicular to grain)	Between fasteners in a row	3
	Between rows	3
	Between staggered rows	1 1/2

For SI: 1 inch = 25.4 mm.

¹Edge distances, end distances and spacing of the screws must be sufficient to prevent splitting of the wood, or as required by this table, whichever is the more restrictive.

² Values for spacing between staggered rows apply where screws in adjacent rows are offset by half of the spacing between screws in a row.

TABLE 5—REFERENCE WITHDRAWAL DESIGN VALUE FOR SDS WOOD SCREWS INSTALLED IN THE SIDE GRAIN OF A WOOD MAIN MEMBER

SDS WOOD SCREW DIMENSIONS (in.)		REFERENCE WITHDRAWAL DESIGN VALUE ^{2,3,4} , W (lbs/inch)
Screw Length, L1	Thread Length ¹ , T	
1 1/2	1	172
1 3/4	1 1/4	
2	1 1/4	
2 1/2	1 1/2	
3	2	
3 1/2	2 1/4	
4 1/2	2 3/4	
5	2 3/4	
6	3 1/4	
8	3 1/4	

For SI: 1 inch = 25.4 mm, 1 lbf/inch = 4.44 kPa.

¹The tabulated reference withdrawal design value (W = 172 lbs/inch) is in pounds per inch of the thread penetration into the side grain of the main member.

²Tabulated reference withdrawal design values (W = 172 lbs/inch) must be multiplied by all applicable adjustment factors from the NDS as referenced in the IBC or IRC.

³Embedded thread length is that portion held in the main member including the screw tip.

⁴The tabulated withdrawal design value (W) is based on wood members having a minimum assigned specific gravity of 0.50, such as Douglas fir–larch. Values are also applicable for fasteners installed into the face of engineered wood described in Section 3.2.2.

TABLE 6—RECOGNIZED EXPOSURE CONDITIONS FOR SIMPSON STRONG-TIE SDS FASTENERS

EXPOSURE CONDITION	TYPICAL APPLICATIONS	RECOGNITION LIMITATIONS
1	Treated Wood in dry use applications	Limited to use where equilibrium moisture content of the chemically treated wood meets the dry services condition as described in the NDS
3	General construction	Limited to freshwater and chemically treated wood exposure, e.g., no saltwater exposure

(This sheet intentionally blank)

SECTION 05 7313 - GLAZED DECORATIVE METAL RAILINGS

PART 1 - GENERAL

1.1 RELATED DOCUMENTS

- A. Drawings and general provisions of the Contract, including General and Supplementary Conditions and Division 01 Specification Sections, apply to this Section.

1.2 SUMMARY

- A. Section Includes:
 - 1. Glass-supported railings.
- B. Related Requirements:
 - 1. Section 06 1053 "Miscellaneous Rough Carpentry" for wood blocking for anchoring railings.

1.3 DEFINITIONS

- A. Railings: Guards, handrails, and similar devices used for protection of occupants at open-sided floor areas and for pedestrian guidance and support, visual separation, or wall protection.

1.4 COORDINATION AND SCHEDULING

- A. Coordinate installation of anchorages for railings. Furnish setting drawings, templates, and directions for installing anchorages, including sleeves, concrete inserts, anchor bolts, and items with integral anchors, that are to be embedded in concrete or masonry. Deliver items to Project site in time for installation.

1.5 ACTION SUBMITTALS

- A. Product Data: For the following:
 - 1. Manufacturer's product lines of railings assembled from standard components.
 - 2. Grout, anchoring cement, and paint products.
- B. Shop Drawings: Include plans, elevations, sections, and attachment details.
- C. Samples for Initial Selection: For products involving selection of color, texture, or design, including mechanical finishes.
- D. Samples for Verification: For each type of exposed finish required.
 - 1. Assembled Samples of railing systems, made from full-size components, including top rail, post, handrail, and infill. Show method of finishing members at intersections. Samples need not be full height.

- E. Delegated-Design Submittal: For installed products indicated to comply with performance requirements and design criteria, including analysis data signed and sealed by the qualified professional engineer responsible for their preparation.

1.6 INFORMATIONAL SUBMITTALS

- A. Qualification Data: For professional engineer.
- B. Mill Certificates: Signed by manufacturers of stainless-steel products certifying that products furnished comply with requirements.
- C. Product Test Reports: Based on evaluation of comprehensive tests performed by a qualified testing agency, according to ASTM E 894 and ASTM E 935.
- D. Evaluation Reports: For post-installed anchors, from ICC-ES.

1.7 FIELD CONDITIONS

- A. Field Measurements: Verify actual locations of walls and other construction contiguous with railings by field measurements before fabrication and indicate measurements on Shop Drawings.

PART 2 - PRODUCTS

2.1 MANUFACTURERS

- A. Manufacturers: Subject to compliance with requirements, provide products by one of the following:
 - 1. Livers Bronze Company – Struct-U-Rail base shoe with US-4 finished cladding.
 - 2. CR Laurence Company – Series B6S base shoe with US-4 finished cladding
 - 3. Julius Blum and Company – Series 1142 base shoe with US-4 finished cladding
 - 4. The Wagner Companies; Series GR2850 base shoe with US-4 finished cladding.
- B. Source Limitations: Obtain each type of railing from single source from single manufacturer.
- C. Product Options: Drawings indicate size, profiles, and dimensional requirements of railings and are based on the specific system indicated. See Section 01 6000 "Product Requirements."
 - 1. Do not modify intended aesthetic effects, as judged solely by Architect, except with Architect's approval. If modifications are proposed, submit comprehensive explanatory data to Architect for review.

2.2 PERFORMANCE REQUIREMENTS

- A. Delegated Design: Engage a qualified professional engineer, as defined in Section 01 4000 "Quality Requirements," to design railings, including attachment to building construction.
- B. General: In engineering railings to withstand structural loads indicated, determine allowable design working stresses of railing materials based on the following:
 - 1. Steel: 72 percent of minimum yield strength.

2. Glass: 25 percent of mean modulus of rupture (50 percent probability of breakage), as listed in "Mechanical Properties" in AAMA's Aluminum Curtain Wall Series No. 12, "Structural Properties of Glass."
- C. Structural Performance: Railings, including attachment to building construction, shall withstand the effects of gravity loads and the following loads and stresses within limits and under conditions indicated:
1. Handrails and Top Rails of Guards:
 - a. Uniform load of 50 lbf/ft. applied in any direction.
 - b. Concentrated load of 200 lbf applied in any direction.
 - c. Uniform and concentrated loads need not be assumed to act concurrently.
 2. Infill of Guards:
 - a. Concentrated load of 50 lbf applied horizontally on an area of 1 sq. ft.
 - b. Infill load and other loads need not be assumed to act concurrently.
 3. Glass-Supported Railings: Support each section of top rail by a minimum of three glass panels or by other means so top rail will remain in place if any one panel fails.

2.3 METALS, GENERAL

- A. Metal Surfaces, General: Provide materials with smooth surfaces, without seam marks, roller marks, rolled trade names, stains, discolorations, or blemishes.
- B. Brackets, Flanges, and Anchors: Same metal and finish as supported rails unless otherwise indicated.

2.4 GLASS AND GLAZING MATERIALS

- A. Safety Glazing: Glazing shall comply with 16 CFR 1201, Category II.
- B. Laminated Glass: ASTM C 1172, Condition A (uncoated), Type I (transparent flat glass), Quality-Q3 with two plies of glass and polyvinyl butyral interlayer not less than 0.060 inch thick.
 1. Kind: LT (laminated tempered).
 2. Glass Color: Clear.
 3. Interlayer Color: Clear.
 4. Glass Plies for Structural Glass Balusters: Thickness required by structural loads, but not less than 8.0 mm thick each.
- C. Safety Glazing Labeling: Permanently mark glass with certification label of the SGCC or another certification agency acceptable to authorities having jurisdiction. Label shall indicate manufacturer's name, type of glass, thickness, and safety glazing standard with which glass complies.
- D. Glazing Cement and Accessories for Structural Glazing: Glazing cement, setting blocks, shims, and related accessories as recommended or supplied by railing manufacturer for installing structural glazing in metal subrails.
 1. Glazing Cement: Nonshrinking organic cement designed for curing by passing an electric current through metal subrail holding glass panel, as standard with manufacturer.

2.5 FASTENERS

- A. Fastener Materials: Unless otherwise indicated, provide the following:
 - 1. Dissimilar Metals: Type 304 stainless-steel fasteners.
- B. Fasteners for Anchoring to Other Construction: Select fasteners of type, grade, and class required to produce connections suitable for anchoring railings to other types of construction indicated and capable of withstanding design loads.
- C. Provide concealed fasteners for interconnecting railing components and for attaching railings to other work unless otherwise indicated.
- D. Post-Installed Anchors: Fastener systems with working capacity greater than or equal to the design load, according to an evaluation report acceptable to authorities having jurisdiction, based on ICC-ES AC193 or ICC-ES AC308.
 - 1. Material for Interior Locations: Carbon-steel components zinc plated to comply with ASTM B 633 or ASTM F 1941, Class Fe/Zn 5, unless otherwise indicated.

2.6 FABRICATION

- A. General: Fabricate railings to comply with requirements indicated for design, dimensions, member sizes and spacing, details, finish, and anchorage, but not less than that required to support structural loads.
- B. Assemble railings in the shop to greatest extent possible to minimize field splicing and assembly. Disassemble units only as necessary for shipping and handling limitations. Clearly mark units for reassembly and coordinated installation. Use connections that maintain structural value of joined pieces.
- C. Cut, drill, and punch metals cleanly and accurately. Remove burrs and ease edges to a radius of approximately 1/32 inch unless otherwise indicated. Remove sharp or rough areas on exposed surfaces.
- D. Form work true to line and level with accurate angles and surfaces.
- E. Fabricate connections that will be exposed to weather in a manner to exclude water. Provide weep holes where water may accumulate. Locate weep holes in inconspicuous locations.
- F. Cut, reinforce, drill, and tap as indicated to receive finish hardware, screws, and similar items.
- G. Mechanical Connections: Connect members with concealed mechanical fasteners and fittings. Fabricate members and fittings to produce flush, smooth, rigid, hairline joints.
 - 1. Fabricate splice joints for field connection using an epoxy structural adhesive if this is manufacturer's standard splicing method.
- H. Bend members in jigs to produce uniform curvature for each configuration required; maintain cross section of member throughout entire bend without buckling, twisting, cracking, or otherwise deforming exposed surfaces of components.
- I. Close exposed ends of hollow railing members with prefabricated end fittings.

2.7 GLAZING PANEL FABRICATION

- A. General: Fabricate to sizes and shapes required; provide for proper edge clearance and bite on glazing panels.
 - 1. Clean-cut or flat-grind edges at butt-glazed sealant joints to produce square edges with slight chamfers at junctions of edges and faces.
 - 2. Grind smooth exposed edges, including those at open joints, to produce square edges with slight chamfers at junctions of edges and faces.
- B. Structural Balusters: Provide laminated, tempered glass panels for both straight and curved sections.

2.8 GENERAL FINISH REQUIREMENTS

- A. Protect mechanical finishes on exposed surfaces from damage by applying a strippable, temporary protective covering before shipment.
- B. Appearance of Finished Work: Noticeable variations in same piece are not acceptable. Variations in appearance of abutting or adjacent pieces are acceptable if they are within one-half of the range of approved Samples. Variations in appearance of other components are acceptable if they are within the range of approved Samples and are assembled or installed to minimize contrast.
- C. Provide exposed fasteners with finish matching appearance, including color and texture, of railings.

PART 3 - EXECUTION

3.1 INSTALLATION, GENERAL

- A. Fit exposed connections together to form tight, hairline joints.
- B. Perform cutting, drilling, and fitting required for installing railings. Set railings accurately in location, alignment, and elevation; measured from established lines and levels and free of rack.
 - 1. Do not weld, cut, or abrade surfaces of railing components that have been coated or finished after fabrication and that are intended for field connection by mechanical or other means without further cutting or fitting.
 - 2. Align rails so variations from level for horizontal members and variations from parallel with rake of steps and ramps for sloping members do not exceed 1/4 inch in 12 feet .
- C. Control of Corrosion: Prevent galvanic action and other forms of corrosion by insulating metals and other materials from direct contact with incompatible materials.
- D. Adjust railings before anchoring to ensure matching alignment at abutting joints.
- E. Fastening to In-Place Construction: Use anchorage devices and fasteners where necessary for securing railings and for properly transferring loads to in-place construction.

3.2 INSTALLING GLASS PANELS

- A. Glass-Supported Railings: Install assembly to comply with railing manufacturer's written instructions.
 - 1. Attach base channel to building structure, then insert and connect factory-fabricated and -assembled glass panels.
 - 2. Attach base channel to building structure, then insert glass into base channel and bond with glazing cement unless glass was bonded to base and top-rail channels in factory.
 - a. Support glass panels in base channel at quarter points with channel-shaped setting blocks that also act as shims to maintain uniform space for glazing cement. Fill remaining space in base channel with glazing cement for uniform support of glass.
 - 3. Adjust spacing of glass panels so gaps between panels are equal before securing in position.
 - 4. Erect glass railings under direct supervision of manufacturer's authorized technical personnel.

3.3 CLEANING

- A. Clean aluminum and stainless steel by washing thoroughly with water and soap, rinsing with clean water, and wiping dry.
- B. Clean and polish glass as recommended in writing by manufacturer. Wash both exposed surfaces in each area of Project not more than four days before date scheduled for inspections that establish date of Substantial Completion.
- C. Clean wood rails by wiping with a damp cloth and then wiping dry.

3.4 PROTECTION

- A. Protect finishes of railings from damage during construction period with temporary protective coverings approved by railing manufacturer. Remove protective coverings at time of Substantial Completion.
- B. Restore finishes damaged during installation and construction period so no evidence remains of correction work. Return items that cannot be refinished in the field to the shop; make required alterations and refinish entire unit, or provide new units.

END OF SECTION 05 7313

SECTION 06 1053 - MISCELLANEOUS ROUGH CARPENTRY

PART 1 - GENERAL

1.1 RELATED DOCUMENTS

- A. Drawings and general provisions of the Contract, including General and Supplementary Conditions and Division 01 Specification Sections, apply to this Section.

1.2 SUMMARY

- A. Section Includes:
 - 1. Wood blocking and nailers.
 - 2. Wood furring.

1.3 DEFINITIONS

- A. Boards or Strips: Lumber of less than 2 inches nominal size in least dimension.
- B. Dimension Lumber: Lumber of 2 inches nominal or greater size but less than 5 inches nominal size in least dimension.

PART 2 - PRODUCTS

2.1 WOOD PRODUCTS, GENERAL

- A. Lumber: DOC PS 20 and applicable rules of grading agencies indicated. If no grading agency is indicated, provide lumber that complies with the applicable rules of any rules-writing agency certified by the ALSC Board of Review. Provide lumber graded by an agency certified by the ALSC Board of Review to inspect and grade lumber under the rules indicated.
 - 1. Factory mark each piece of lumber with grade stamp of grading agency.
 - 2. Dress lumber, S4S, unless otherwise indicated.

2.2 MISCELLANEOUS LUMBER

- A. General: Provide miscellaneous lumber indicated and lumber for support or attachment of other construction, including the following:
 - 1. Blocking.
 - 2. Nailers.
 - 3. Furring.
- B. For blocking not used for attachment of other construction, Utility, Stud, or No. 3 grade lumber of any species may be used provided that it is cut and selected to eliminate defects that will interfere with its attachment and purpose.

- C. For blocking and nailers used for attachment of other construction, select and cut lumber to eliminate knots and other defects that will interfere with attachment of other work.
- D. For furring strips for installing plywood or hardboard paneling, select boards with no knots capable of producing bent-over nails and damage to paneling.

2.3 FASTENERS

- A. General: Provide fasteners of size and type indicated that comply with requirements specified in this article for material and manufacture.
- B. Power-Driven Fasteners: Fastener systems with an evaluation report acceptable to authorities having jurisdiction, based on ICC-ES AC70.

2.4 MISCELLANEOUS MATERIALS

- A. Adhesives for Gluing Furring to Concrete or Masonry: Formulation complying with ASTM D 3498 that is approved for use indicated by adhesive manufacturer.

PART 3 - EXECUTION

3.1 INSTALLATION, GENERAL

- A. Framing Standard: Comply with AF&PA's WCD 1, "Details for Conventional Wood Frame Construction," unless otherwise indicated.
- B. Set carpentry to required levels and lines, with members plumb, true to line, cut, and fitted. Fit carpentry accurately to other construction. Locate furring, nailers, blocking, and similar supports to comply with requirements for attaching other construction.
- C. Install plywood backing panels by fastening to studs; coordinate locations with utilities requiring backing panels.
- D. Install metal framing anchors to comply with manufacturer's written instructions. Install fasteners through each fastener hole.
- E. Provide blocking and framing as indicated and as required to support facing materials, fixtures, specialty items, and trim.
- F. Securely attach carpentry work to substrate by anchoring and fastening as indicated, complying with the following:
 - 1. Table 2304.9.1, "Fastening Schedule," in ICC's International Building Code.
 - 2. ICC-ES evaluation report for fastener.

3.2 WOOD BLOCKING AND NAILER INSTALLATION

- A. Install where indicated and where required for attaching other work. Form to shapes indicated and cut as required for true line and level of attached work. Coordinate locations with other work involved.

- B. Attach items to substrates to support applied loading. Recess bolts and nuts flush with surfaces unless otherwise indicated.
- C. Provide permanent grounds of dressed, pressure-preservative-treated, key-beveled lumber not less than 1-1/2 inches wide and of thickness required to bring face of ground to exact thickness of finish material. Remove temporary grounds when no longer required.

3.3 WOOD FURRING INSTALLATION

- A. Install level and plumb with closure strips at edges and openings. Shim with wood as required for tolerance of finish work.

END OF SECTION 06 1053

(This sheet intentionally blank)

SECTION 06 1600 - SHEATHING

PART 1 - GENERAL

1.1 RELATED DOCUMENTS

- A. Drawings and general provisions of the Contract, including General and Supplementary Conditions and Division 01 Specification Sections, apply to this Section.

1.2 SUMMARY

- A. Section Includes:
 - 1. Subflooring.
- B. Related Requirements:
 - 1. Section 06 1053 "Miscellaneous Rough Carpentry" for plywood backing panels.

1.3 ACTION SUBMITTALS

- A. Product Data: For each type of process and factory-fabricated product. Indicate component materials and dimensions and include construction and application details.

1.4 DELIVERY, STORAGE, AND HANDLING

- A. Stack panels flat with spacers beneath and between each bundle to provide air circulation. Protect sheathing from weather by covering with waterproof sheeting, securely anchored. Provide for air circulation around stacks and under coverings.

PART 2 - PRODUCTS

2.1 WOOD PANEL PRODUCTS

- A. Thickness: As needed to comply with requirements specified, but not less than thickness indicated.
- B. Factory mark panels to indicate compliance with applicable standard.
- C. Kiln-dry material after treatment to a maximum moisture content of 15 percent. Do not use material that is warped or does not comply with requirements for untreated material.
- D. Identify fire-retardant-treated plywood with appropriate classification marking of qualified testing agency.

2.2 SUBFLOORING AND UNDERLAYMENT

- A. Plywood Combination Subfloor-Underlayment: DOC PS 1, Exterior, Structural I, C-C Plugged single-floor panels.
 - 1. Span Rating: Not less than 24.
 - 2. Nominal Thickness: Not less than Match existing (23/32 inch).
 - 3. Edge Detail: Square.
 - 4. Surface Finish: Fully sanded face.

2.3 FASTENERS

- A. General: Provide fasteners of size and type indicated that comply with requirements specified in this article for material and manufacture.
- B. Power-Driven Fasteners: Fastener systems with an evaluation report acceptable to authorities having jurisdiction, based on ICC-ES AC70.
- C. Screws for Fastening Sheathing to Wood Framing: ASTM C 1002.

2.4 MISCELLANEOUS MATERIALS

- A. Adhesives for Field Gluing Panels to Wood Framing: Formulation complying with APA AFG-01 that is approved for use with type of construction panel indicated by manufacturers of both adhesives and panels.

PART 3 - EXECUTION

3.1 INSTALLATION, GENERAL

- A. Do not use materials with defects that impair quality of sheathing or pieces that are too small to use with minimum number of joints or optimum joint arrangement. Arrange joints so that pieces do not span between fewer than three support members.
- B. Cut panels at penetrations, edges, and other obstructions of work; fit tightly against abutting construction unless otherwise indicated.
- C. Securely attach to substrate by fastening as indicated, complying with the following:
 - 1. Table 2304.9.1, "Fastening Schedule," in the ICC's International Building Code.
 - 2. ICC-ES evaluation report for fastener.
- D. Use common wire nails unless otherwise indicated. Select fasteners of size that will not fully penetrate members where opposite side will be exposed to view or will receive finish materials. Make tight connections. Install fasteners without splitting wood.
- E. Coordinate sheathing installation with installation of materials installed over sheathing so sheathing is not exposed to precipitation or left exposed at end of the workday when rain is forecast.

3.2 WOOD STRUCTURAL PANEL INSTALLATION

- A. General: Comply with applicable recommendations in APA Form No. E30, "Engineered Wood Construction Guide," for types of structural-use panels and applications indicated.
- B. Fastening Methods: Fasten panels as indicated below:
 - 1. Combination Subfloor-Underlayment:
 - a. Glue and nail to wood framing.
 - b. Space panels 1/8 inch apart at edges and ends.

END OF SECTION 06 1600

(This sheet intentionally blank)

SECTION 09 9123 - INTERIOR PAINTING

PART 1 - GENERAL

1.1 RELATED DOCUMENTS

- A. Drawings and general provisions of the Contract, including General and Supplementary Conditions and Division 01 Specification Sections, apply to this Section.

1.2 SUMMARY

- A. Section includes surface preparation and the application of paint systems on the following interior substrates:
 - 1. Wood.

1.3 DEFINITIONS

- A. MPI Gloss Level 1: Not more than five units at 60 degrees and 10 units at 85 degrees, according to ASTM D 523.
- B. MPI Gloss Level 2: Not more than 10 units at 60 degrees and 10 to 35 units at 85 degrees, according to ASTM D 523.
- C. MPI Gloss Level 3: 10 to 25 units at 60 degrees and 10 to 35 units at 85 degrees, according to ASTM D 523.
- D. MPI Gloss Level 4: 20 to 35 units at 60 degrees and not less than 35 units at 85 degrees, according to ASTM D 523.
- E. MPI Gloss Level 5: 35 to 70 units at 60 degrees, according to ASTM D 523.
- F. MPI Gloss Level 6: 70 to 85 units at 60 degrees, according to ASTM D 523.
- G. MPI Gloss Level 7: More than 85 units at 60 degrees, according to ASTM D 523.

1.4 ACTION SUBMITTALS

- A. Product Data: For each type of product. Include preparation requirements and application instructions.
- B. Samples for Verification: For each type of paint system and in each color and gloss of topcoat.
 - 1. Submit Samples on rigid backing, 8 inches square.

1.5 DELIVERY, STORAGE, AND HANDLING

- A. Store materials not in use in tightly covered containers in well-ventilated areas with ambient temperatures continuously maintained at not less than 45 deg. F.
 - 1. Maintain containers in clean condition, free of foreign materials and residue.

2. Remove rags and waste from storage areas daily.

PART 2 - PRODUCTS

2.1 MANUFACTURERS

- A. Manufacturers: Subject to compliance with requirements, available manufacturers offering products that may be incorporated into the Work include, but are not limited to, the following:
 1. Benjamin Moore & Co;
 2. Glidden Professional.
 3. PPG Architectural Coatings.
 4. Pratt & Lambert.
 5. Sherwin-Williams Company (The);
 6. Valspar Corporation - Architectural (Pro);
- B. Products: Subject to compliance with requirements, available products that may be incorporated into the Work include, but are not limited to products listed in the Interior Painting Schedule for the paint category indicated.

2.2 PAINT, GENERAL

- A. MPI Standards: Products shall comply with MPI standards indicated and shall be listed in its "MPI Approved Products Lists."
- B. Material Compatibility:
 1. Materials for use within each paint system shall be compatible with one another and substrates indicated, under conditions of service and application as demonstrated by manufacturer, based on testing and field experience.
 2. For each coat in a paint system, products shall be recommended in writing by topcoat manufacturers for use in paint system and on substrate indicated.
- C. Colors: Match existing.

PART 3 - EXECUTION

3.1 EXAMINATION

- A. Examine substrates and conditions, with Applicator present, for compliance with requirements for maximum moisture content and other conditions affecting performance of the Work.

3.2 PREPARATION

- A. Comply with manufacturer's written instructions and recommendations in "MPI Architectural Painting Specification Manual" applicable to substrates and paint systems indicated.
- B. Wood Substrates:
 1. Scrape and clean knots, and apply coat of knot sealer before applying primer.
 2. Sand surfaces that will be exposed to view, and dust off.
 3. Prime edges, ends, faces, undersides, and backsides of wood.

4. After priming, fill holes and imperfections in the finish surfaces with putty or plastic wood filler. Sand smooth when dried.

3.3 APPLICATION

- A. Apply paints according to manufacturer's written instructions and to recommendations in "MPI Manual."
 1. Use applicators and techniques suited for paint and substrate indicated.
 2. Paint surfaces behind movable equipment and furniture same as similar exposed surfaces. Before final installation, paint surfaces behind permanently fixed equipment or furniture with prime coat only.
 3. Paint front and backsides of access panels, removable or hinged covers, and similar hinged items to match exposed surfaces.
 4. Do not paint over labels of independent testing agencies or equipment name, identification, performance rating, or nomenclature plates.
 5. Primers specified in painting schedules may be omitted on items that are factory primed or factory finished if acceptable to topcoat manufacturers.
- B. If undercoats or other conditions show through topcoat, apply additional coats until cured film has a uniform paint finish, color, and appearance.
- C. Apply paints to produce surface films without cloudiness, spotting, holidays, laps, brush marks, roller tracking, runs, sags, ropiness, or other surface imperfections. Cut in sharp lines and color breaks.

3.4 CLEANING AND PROTECTION

- A. At end of each workday, remove rubbish, empty cans, rags, and other discarded materials from Project site.
- B. After completing paint application, clean spattered surfaces. Remove spattered paints by washing, scraping, or other methods. Do not scratch or damage adjacent finished surfaces.
- C. Protect work of other trades against damage from paint application. Correct damage to work of other trades by cleaning, repairing, replacing, and refinishing, as approved by Architect, and leave in an undamaged condition.
- D. At completion of construction activities of other trades, touch up and restore damaged or defaced painted surfaces.

3.5 INTERIOR PAINTING SCHEDULE

- A. Wood Substrates: Wood trim.
 1. Latex over Latex Primer System MPI INT 6.3T:
 - a. Prime Coat: Primer, latex, for interior wood, MPI #39.
 - b. Intermediate Coat: Latex, interior, matching topcoat.
 - c. Topcoat: Latex, interior, gloss (MPI Gloss Level 6, except minimum gloss of 65 units at 60 degrees), MPI #114.

END OF SECTION 09 9123

(This sheet intentionally blank)